

cue

keypadCUE-55

User Manual

CONTENTS

2	CONTENTS
3	INTRODUCTION
3	Overview
3	Model
3	Main Features
3	Programming
3	Box Contents
3	Order Information
4	Available Accessories (has to be ordered separately)
5	SPECIFICATIONS
5	MECHANICAL DESCRIPTION
6	CONNECTION
6	6P6C modular jack connector RS-485 & power supply (CUEwire)
6	Example 1 - connection to controlCUE-basic
6	Example 2 - connection to controlCUE-one
6	Example 3 - connection to controlCUE-versatile
8	BUTTON LABELS
10	ADDRESSING
11	MOUNTING
11	Wall installation
12	Interconnection Tabletop Box Installation
13	SOFTWARE AND FIRMWARE LICENSE
14	NOTES

INTRODUCTION

Overview

keypadCUE-55 is a fully customizable button control panel compatible with all CUE controllers. This easy-to-use control interface connects to controllers to offer a wide variety of functions such as display on and off, input switching, volume and mute control, etc. The keypad provides eight buttons and programmable indication in each button. Each button can be configured for any function. User-defined button label can be printed on a printer and inserted into the keypad. Featuring a beautiful architectural finish, this keypad is an elegant and powerful wall-mounted control panel designed to be installed onto a standard European electrical wall box as well as into a cable enclosure.

Model

Model	Product Code	Description	Note
keypadCUE-55	CS0542-9006	Keypad with white aluminium RAL9006 enclosure	
keypadCUE-55	CS0542-9003	Keypad with signal white RAL9003 enclosure	

Main Features

- 8 buttons
- Programmable LED indication for each button
- User defined button's label with backlight
- Beautiful architectural finish
- On-wall installation
- Compatible with standard European wall boxes
- System connection by CUEwire (RS-485 + power)

Programming

keypadCUE-55 is programmed using the Cue Visual Composer (CVC) programming tool. Control commands are described in the CVC help, part CUEdevices, chapters Configuration/CUEwire and keypadCUE-55. This model is not compatible with older programming tool Cue System Director.

Box Contents







Keypad keypadCUE-55
 2x 6P4C cable connector
 Mounting screws
 Quick Start
 Declaration of Conformity & Warranty Conditions

Order Information

Product codes

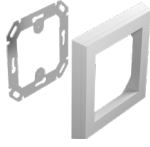
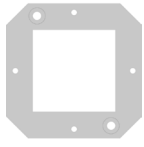
- CS0542-9006 white aluminium RAL9006 enclosure
- CS0542-9003 signal white RAL9003 enclosure

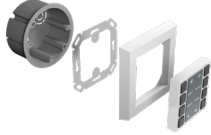
Available Accessories (has to be ordered separately)

				
	Tabletop Holder 55	Under Desk Holder 55	Wall Set 55	Pan Adapter 55
Product code	CS0586	CS0587	CS0583	CS0584
Description	Allows to install keypad on the top of the table. It attaches on the top side of the table desk.	This holder allows to install keypad under the table. It attaches to the under side of the table desk.	This set allows to install keypad on the wall. It is fully compatible with standard electrical wall boxes.	This adapter allows to install keypad into PANCONNECT boxes that are not prepared for CUE products.
Enclosure	Grey metal	Grey metal	Metal wall adapter White plastic frame	Metal
Dimensions	55 x 47 x 55 mm	55 x 100 x 34 mm	Frame 81 x 81 x 10.7 mm	49.5 x 49.5 x 2 mm
Weight	80 g	85 g	40 g	10 g
Application				

SPECIFICATIONS

Buttons

- 8x black plastic button
- Fully configurable functionality

Indication

- 8x programmable green LED in each button
- Variable brightness

Button's label

- White backlight with variable brightness
- Black background and white characters recommended
- Print on a printer or use 3M ScotchMark laser markable label stock 7847 - two-layer film designed for the production of labels in laser marking facilities.

System connection

- Power supply 10 ÷ 30 VDC, max. 2 W
- RS-485 data communication
- 2x 6P6C modular jack connector

Physical

- Aluminium enclosure
- Enclosure colors: white aluminium RAL9006 or pure white RAL9003
- Protection IP30
- Dimensions 55 x 55 x 11 mm / 2.2" x 2.2" x 0.4"
- Weight 0.09 kg / 0.2 lb

Operating environment

- Temperature 10° ÷ 40° C
- Humidity 10% ÷ 90% non-condensing

Environment conditions

- Operating temperature 10° ÷ 40° C
- Storage temperature 0° ÷ 60° C
- Relative humidity 10% ÷ 90% non-condensing

Supplied accessories

- 2x 6P4C cable connector

MECHANICAL DESCRIPTION

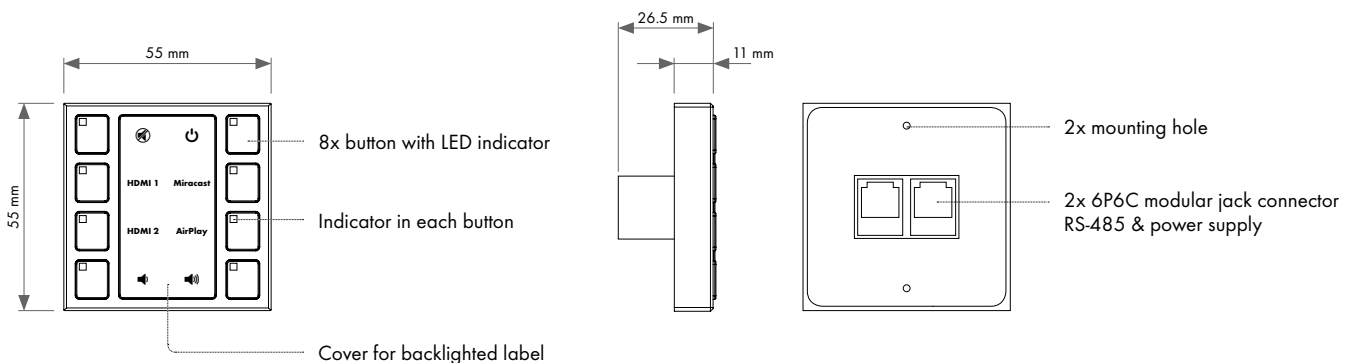

The front panel is equipped with 8 buttons, each with an indication LED, and a backlitged area for the label - see picture.

Button LEDs brightness and their ON or OFF state are controlled by special programming commands from the controller. Brightness of backlight can be also set by special programming commands from the controller.

CONNECTION

6P6C modular jack connector RS-485 & power supply (CUEwire)

6P6C connector RS-485 & power supply

Pin	Description
1	+10 ÷ +30 V DC
2	+10 ÷ +30 V DC
3	A+
4	B-
5	Ground
6	Ground

rear-side view

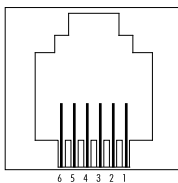

Example 1 - connection to controlCUE-basic

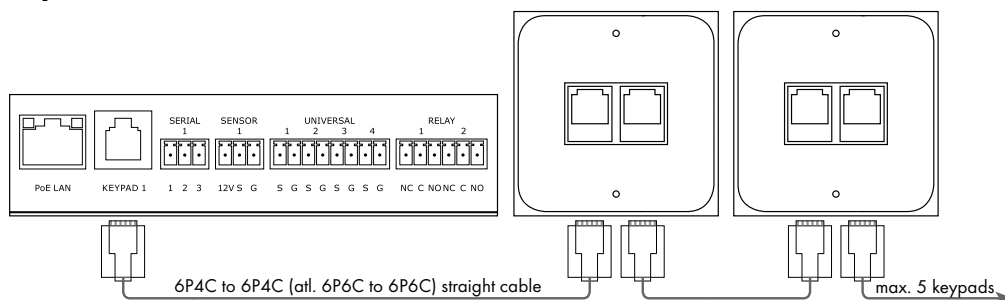

Example 2 - connection to controlCUE-one

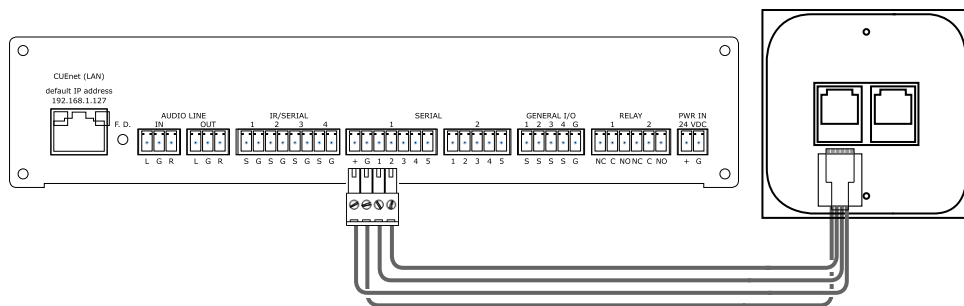

Example 3 - connection to controlCUE-versatile

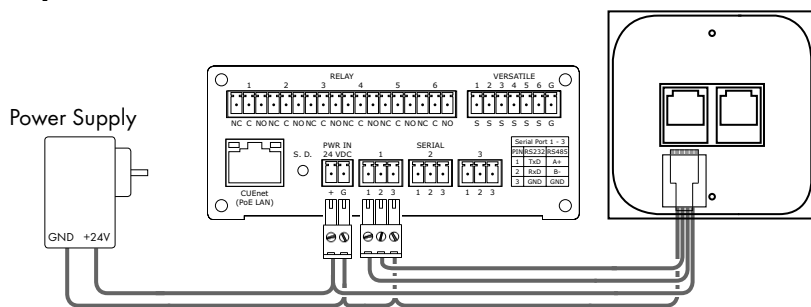

Multiple keypads or other CUEwire devices can be connected in parallel. In this case the following conditions must be met:

- Each keypad (or other device) has a unique ADDRESS.
- The power supply should be properly selected to have sufficient power for all keypads and other devices powered by it, incl. the controller. Each keypadCUE-55 requires 2W. For other devices, the consumption is stated in the datasheets. controlCUE-basic allows a maximum of 5 keypads to be connected.
- The cable cross section must be designed according to length and consumption in individual locations. For shorter cables and a limited number of devices 4 conductor flat phone line cord or CATx cable can be used.
- Maximum of 30 devices can be connected to the one CUEwire (RS-485 + power) line.
- For wiring it is recommended to use the bus topology. The maximum length of all cables should not exceed 900 m.
- As there may be voltage drops due to wire resistance on the cable, check whether the supply voltage measured by the individual devices is within their permitted range.

BUTTON LABELS

For keypadCUE-55, custom label for button description can be used. The label can be printed on paper or transparent foil. Great results can be obtained using 3M ScotchMark laser markable label stock 7847 - a two-layer film designed for the production of labels in laser marking facilities.

Steps:

1. Create the label in your favorite graphic program, place the required white texts / icons on black background and print it. **Don't use black texts / icons on white background.**

The size and label layout is pictured below. Recommended fonts are Nimbus, Trebuchet, Verdana, SegoeUI or Arial, size 6 points, bold. You can use templates in various formats available on the product webpage. We strongly recommend placing the labels in the area marked with a gray rectangle because that is where backlight LEDs are placed.

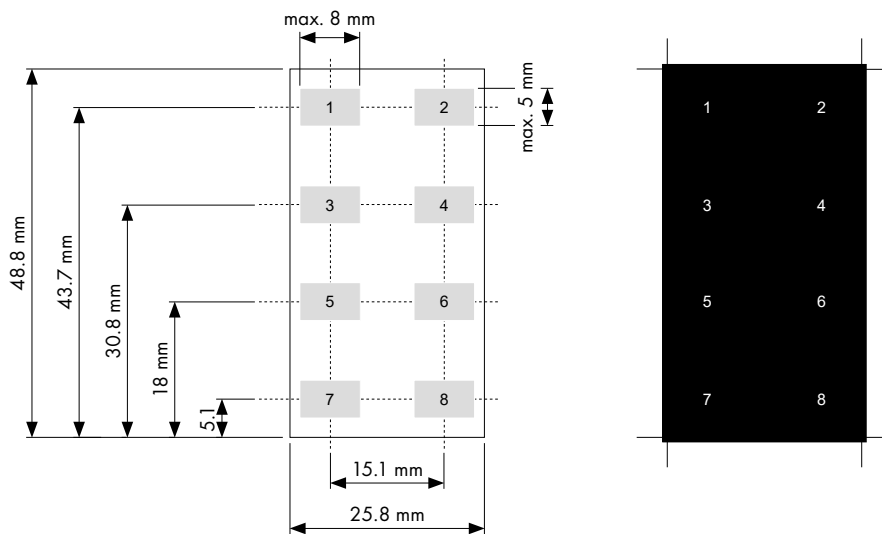

2. Using small flat screwdriver remove the transparent cover.

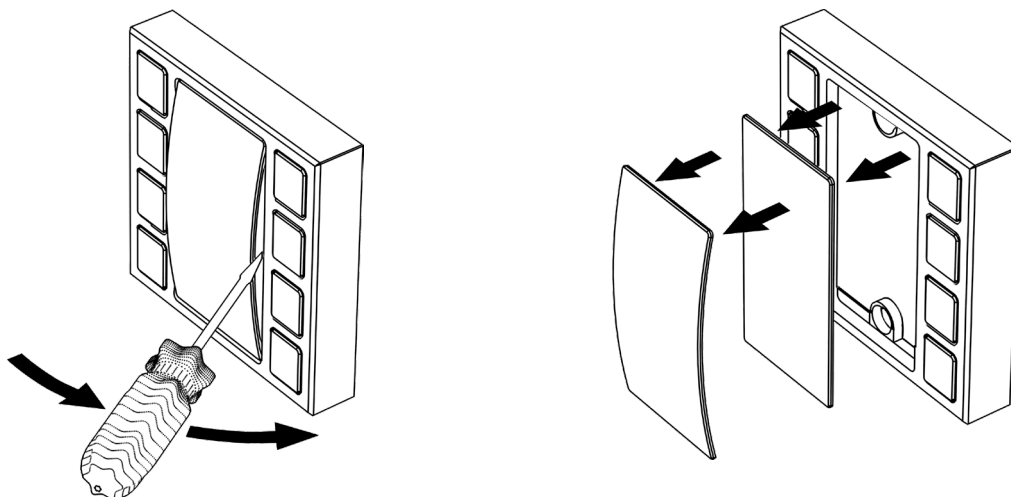

3. Place the diffuser and printed label into the keypad. Then put the transparent cover over them. In doing that, insert the transparent cover under one side of the keypad and bend it slightly until it is possible to insert the other side of the cover as well.

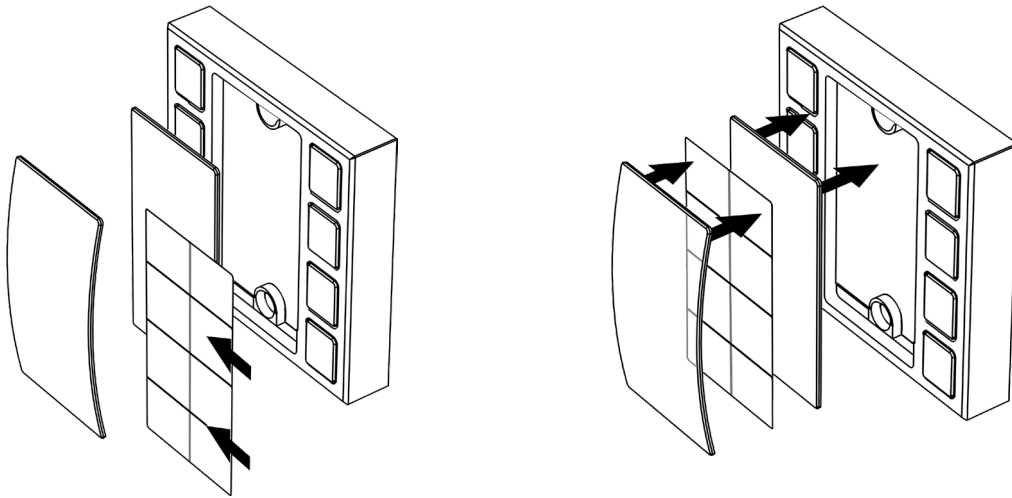

ADDRESSING

Each keypadCUE-55 is identified by an ADDRESS. This ADDRESS must be unique within the units connected to one RS-485 (CUEwire) line.

- The ADDRESS can be set in the range 2 to 30.
- Default ADDRESS is 2.
- The address set in the keypad must match the address in the Cue Visual Composer project configuration.

The address of the keypadCUE-55 is stored in the internal flash memory. For modification of the address do the following:

- Unplug the connection cable.
- Press and hold the left and right bottom buttons and plug the connection cable. This will bring the keypad into the address setting mode. The right bottom LED will blink. You can now release both buttons.

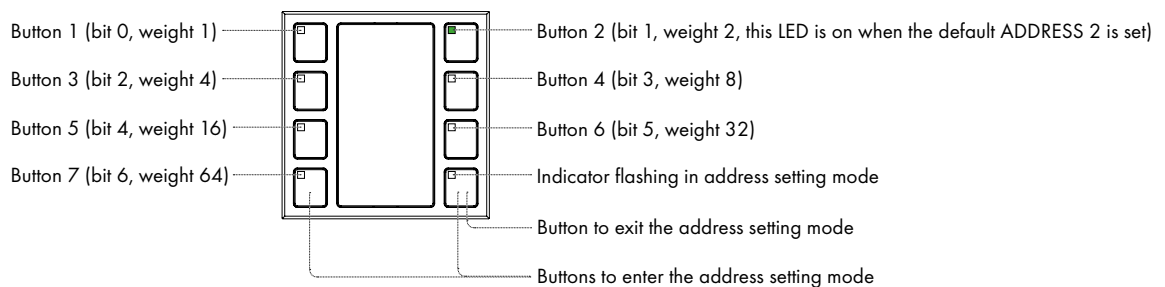

- The LEDs for button 1 - 7 indicate ADDRESS in binary code – Button 1 bit 0, Button 2 bit 1 etc... Push buttons to toggle address bits to the requested value of ADDRESS (see table below).

ADDRESS	Button LEDs (0 = Off, 1 = On)						
	Button 1 Bit 0 Weight 1	Button 2 Bit 1 Weight 2	Button 3 Bit 2 Weight 4	Button 4 Bit 3 Weight 8	Button 5 Bit 4 Weight 16	Button 6 Bit 5 Weight 32	Button 7 Bit 6 Weight 64
2 (default)	0	1	0	0	0	0	0
3	1	1	0	0	0	0	0
4	0	0	1	0	0	0	0
5	1	0	1	0	0	0	0
6	0	1	1	0	0	0	0
7	1	1	1	0	0	0	0
8	0	0	0	1	0	0	0
9	1	0	0	1	0	0	0
10	0	1	0	1	0	0	0
11	1	1	0	1	0	0	0
12	0	0	1	1	0	0	0
13	1	0	1	1	0	0	0
14	0	1	1	1	0	0	0
15	1	1	1	1	0	0	0
16	0	0	0	0	1	0	0
17	1	0	0	0	1	0	0
18	0	1	0	0	1	0	0
19	1	1	0	0	1	0	0
20	0	0	1	0	1	0	0
21	1	0	1	0	1	0	0
22	0	1	1	0	1	0	0
23	1	1	1	0	1	0	0
24	0	0	0	1	1	0	0
25	1	0	0	1	1	0	0
26	0	1	0	1	1	0	0
27	1	1	0	1	1	0	0
28	0	0	1	1	1	0	0
29	1	0	1	1	1	0	0
30	0	1	1	1	1	0	0

- After setting the address, press the right bottom key. This saves the address and the keyboard enters the normal operating mode.

MOUNTING

Wall installation

keypadCUE-55 is fully compatible with standard electrical wall boxes. Wall adapter for simple and quick installation and white plastic frame are supplied as an optional accessory. Wall Set 55 (wall adapter & plastic frame, CS0583) has to be ordered separately.

Installation steps are as follows:

1. Install the wall adapter on the electrical wall box using appropriate fasteners. Keep maximum screw dimensions as described below.

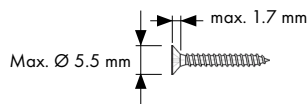

2. Using small flat screwdriver remove the transparent cover and diffuser.

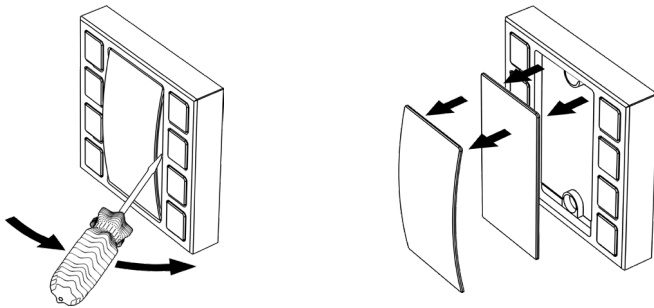

3. Plug the connection cable and insert the keypad with plastic frame into the wall adapter.
4. Attach the keypad using the mounting screws M 2.5 x 12.

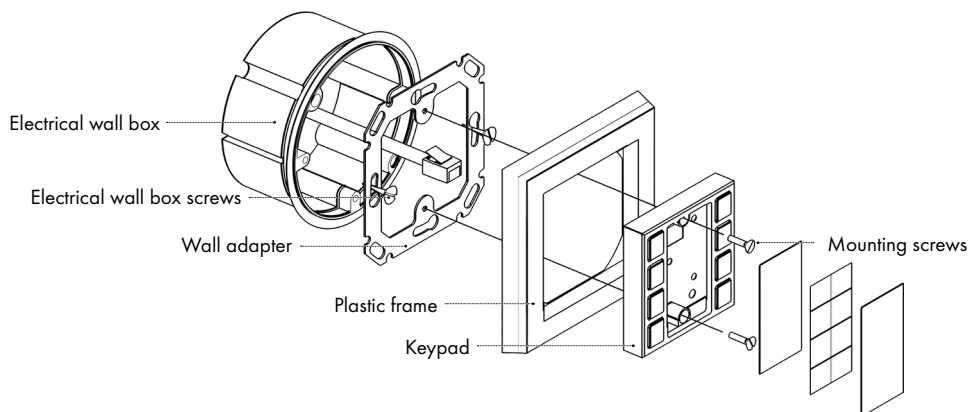

5. Place the diffuser and printed label into the keypad. Then put the transparent cover over them. In doing that, insert the transparent cover under one side of the keypad and bend it slightly until it is possible to insert the other side of the cover as well.

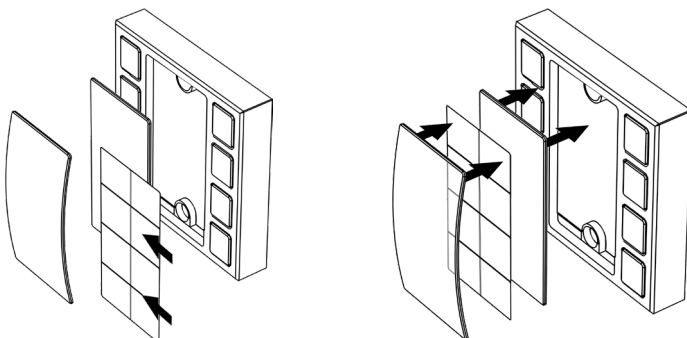

Interconnection Tabletop Box Installation

keypadCUE-55 is fully compatible with PANCONNECT interconnection tabletop boxes. This type of installation is suitable for simple room control systems. The PANCONNECT interconnection box must be equipped with an Pan Adapter 55 for 55x55 mm module mounting. Pan Adapter 55 (CS0584) has to be ordered separately.

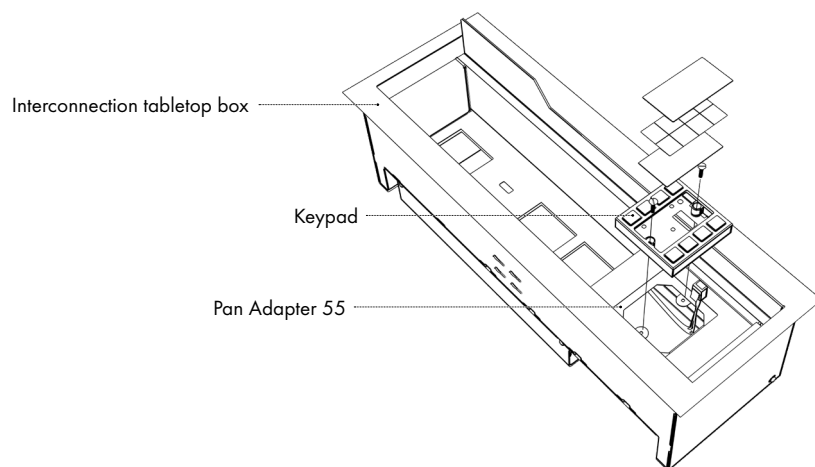

For installation, remove transparent cover and diffusor as described above. Then plug the connection cable and attach the keypad into the Pan Adapter 55 using the mounting screws M 2.5. Finally, place back diffusor, printed label and transparent cover.

SOFTWARE AND FIRMWARE LICENSE

END-USER NOTICE AND LICENSE AGREEMENT FROM CUE, a.s.

NOTICE TO END-USER: CAREFULLY READ THE FOLLOWING LEGAL AGREEMENT (THIS "LICENSE").

INSTALLATION OR USE OF THE ENCLOSED CUE, a.s. SOFTWARE PROGRAMS (COLLECTIVELY, "SOFTWARE") ON YOUR COMPUTER SYSTEMS OR HARDWARE DEVICES CONSTITUTES YOUR ACCEPTANCE OF THESE TERMS. IF YOU DO NOT AGREE TO THE TERMS OF THIS LICENSE, PROMPTLY DELETE THE SOFTWARE FROM YOUR COMPUTER SYSTEMS AND HARDWARE DEVICES, DESTROY ANY COPIES YOU MADE OF THE SOFTWARE OR ANY INSTALLATION MEDIA OF THE SOFTWARE INCLUDED WITH YOUR SYSTEM, AND DISPOSE OF ALL WRITTEN MATERIALS IN YOUR POSSESSION REGARDING THE SOFTWARE.

License Grant: CUE grants to You, as an individual, a license to install and use one (1) copy of the Software on a single computer at a time; provided, however, that You may make copies of the Software solely for Your development of applications for CUE hardware and demonstration versions of such applications. Any applications created with the Software may only be used with Cue hardware. Your license to use the Software is conditioned upon Your compliance with the terms of this License. A License is required for each end-user of the Software. A license is required for each installation of the Software. You may make one (1) copy of the Software for archival purposes only. You may use this Software only in connection with CUE hardware. You must have acquired the Software directly in connection with the purchase of CUE hardware from CUE or from a CUE approved reseller for this license to be effective. If You have purchased a Site License, You may complete only the number of installations specified in the License Agreement accompanying the Software.

Copyright: The Software and software built into CUE hardware ("Firmware") are protected by copyright law and international treaty provisions. You acknowledge that no title to the intellectual property in the Software and Firmware is transferred to You. You further acknowledge that title and full ownership rights to the Software and Firmware will remain the exclusive property of CUE, and You will not acquire any rights to the Software and Firmware except as expressly set forth in this License. You agree that any copies of the Software will contain the same proprietary notices which appear on and in the Software.

Prohibited Uses: Without obtaining prior written permission from CUE, You may not (a.) use, copy, modify, alter, or transfer the Software or documentation except as expressly provided in this License; (b.) translate, disassemble, decompile, reverse program or otherwise reverse engineer the Software and Firmware; (c.) sublicense or lease the Software or its documentation (d.) use this Software with any hardware other than products produced by CUE or in connection with applications being developed for CUE hardware; or (e.) use the Software in a multi-user, network, or multiple computer environment or in a rental, time sharing or computer service business. Without prejudice to any other rights, CUE may terminate this License if You fail to comply with its terms and conditions. In such event, You must immediately destroy all copies of the Software.

AVC Video Restrictions: THIS PRODUCT IS LICENSED UNDER THE AVC PATENT PORTFOLIO LICENSE FOR THE PERSONAL USE OF A CONSUMER OR OTHER USES IN WHICH IT DOES NOT RECEIVE REMUNERATION TO (i) ENCODE VIDEO IN COMPLIANCE WITH THE AVC STANDARD ("AVC VIDEO") AND/OR (ii) DECODE AVC VIDEO THAT WAS ENCODED BY A CONSUMER ENGAGED IN A PERSONAL ACTIVITY AND/OR WAS OBTAINED FROM A VIDEO PROVIDER LICENSED TO PROVIDE AVC VIDEO. NO LICENSE IS GRANTED OR SHALL BE IMPLIED FOR ANY OTHER USE. ADDITIONAL INFORMATION MAY BE OBTAINED FROM MPEG LA, L.L.C. SEE <http://www.mpegla.com>.

No Other Warranties: CUE DOES NOT WARRANT THAT THE SOFTWARE AND FIRMWARE IS ERROR FREE. CUE DISCLAIMS ALL WARRANTIES WITH RESPECT TO THE SOFTWARE AND FIRMWARE, EITHER EXPRESS OR IMPLIED, INCLUDING BUT NOT LIMITED TO IMPLIED WARRANTIES OF MERCHANTABILITY, FITNESS FOR A PARTICULAR PURPOSE AND NON-INFRINGEMENT OF THIRD PARTY RIGHTS. SOME JURISDICTIONS DO NOT ALLOW THE EXCLUSION OF IMPLIED WARRANTIES OR LIMITATIONS OF HOW LONG AN IMPLIED WARRANTY MAY LAST, OR THE EXCLUSION OF LIMITATION OF INCIDENTAL DAMAGES, SO THE ABOVE LIMITATIONS OR EXCLUSIONS MAY NOT APPLY TO YOU. THIS WARRANTY GIVES YOU SPECIFIC LEGAL RIGHTS AND YOU MAY ALSO HAVE OTHER RIGHTS WHICH VARY FROM JURISDICTION TO JURISDICTION.

No Liability for Consequential Damages: IN NO EVENT SHALL CUE BE LIABLE TO YOU FOR ANY CONSEQUENTIAL, SPECIAL, INCIDENTAL, OR INDIRECT DAMAGES OF ANY KIND ARISING OUT OF THE PERFORMANCE OR USE OF THE SOFTWARE, EVEN IF CUE HAS BEEN ADVISED OF THE POSSIBILITY OF SUCH DAMAGES.

Label on Hardware: Use of this hardware and the software programs controlling this hardware is subject to the terms of the Software and Hardware License Agreements (the "License Agreements"). You should not use the software and hardware until you have read the License Agreements. By using the software and hardware, you signify that you have read the Licenses Agreements and accept their terms. The "License Agreement" is available at www.cuesystem.com.

Trademark Notice: CUE and the CUE logo are trademarks of CUE, a.s. in the United States and in other countries.

